

객체지향개발방법론

OOAD 2040

(Object-Oriented Design)

201212519 컴퓨터공학과 김선우
201510624 컴퓨터공학과 김용현
201614157 컴퓨터공학과 김도연
201614158 컴퓨터공학과 장다혜

DWS Define Requirements

< Functional Requirements >

1. 현재 시간

- 사용자가 나라, 날짜 및 시간 설정을 한다.
- 현재 날짜를 출력한다.
- 현재 시간을 출력한다.
- 오후 시간 표시는 24시로 표현한다.

2. 스탑워치 기능

- 시간의 경과를 알려준다.
- 1/100초 단위로 측정한다.
- 일시정지/재시작이 가능하다.

3. 알람 기능

- 알람 시간은 4개까지 저장 가능하다.
- 알람은 3초 후에 꺼지거나, 버튼을 누르면 꺼진다.
- 알람 기능을 켜면 화면에 표시된다.

4. 타이머 기능

- 타이머 시간을 설정한다.
- 시간이 다되면 알람이 울린다.
- 타이머 일시정지 가능하다.
- 시간이 초과되면 초기화된다.

5. 세계시간 기능

- 한국, 미국, 영국, 중국, 러시아, 싱가포르의 시간을 제공할 수 있다.
- 선택한 나라의 날짜를 출력한다.
- 선택한 나라의 시간을 출력한다.

6. 밝기 조절 기능

- 시간에 따라 화면 밝기가 자동 조절된다.
- 밝기 수준을 선택할 수 있다.

7. 기능 선택 기능

- 6가지의 기능 중 4가지를 선택할 수 있다.
- 기능 변경이 되어도 알람 시간은 항상 저장된다.

Activity 2041 :
Design Real Use Cases

Use case	1. Set Time
Actor	User
Type	Evident
Pre-Requisites	currentState의 값이 0이어야 한다.
Typical Courses of Events	<p>(A) : Actor, (S) : System</p> <ol style="list-style-type: none"> 1. (A) : User가 A 버튼을 누른다. 2. (S) : reqSetTime()을 호출한다. 3.1 (S) : enterSetSection()을 호출한다. <ul style="list-style-type: none"> (S) : display()를 호출한다. 4.1.1 (A) : 사용자가 B 버튼을 누른다, 4.1.2 (S) : nextWorld()를 호출한다. 4.1.3 (S) : display(world)를 호출한다 4.2.1 (A) : 사용자가 D 버튼을 누른다, 4.2.2 (S) : previousWorld()를 호출한다. 4.2.3 (S) : display(world)를 호출한다 4.3.1 (A) : 사용자가 버튼을 누른다, 4.3.2 (S) : changeValue(currentState :int , button : int)를 호출한다. 4.3.3 (S) : display(world)를 호출한다

Alternative Courses of Events	A1. 각 설정화면에서 C 버튼을 누르면 Timekeeping 모드로 돌아간다.
Exceptional Courses of Event	<p>E1. year값이 2100 일 때, B 버튼을 눌러 증가시키면 2000이 된다. 2000 일 때, D 버튼을 눌러 감소시키면 2100이 된다.</p> <p>E2. month값이 12 일 때, B 버튼을 눌러 증가시키면 1 이 된다. 1 일 때, D 버튼을 눌러 감소시키면 12 이 된다.</p> <p>E3. day값이 month 값에 따라 30, 31 일 때, B 버튼을 눌러 증가시키면 1 이 된다. month 값에 따라 1 일 때, D 버튼을 눌러 감소시키면 30, 31 이 된다.</p> <p>E4. hour값이 24H 일 때, B 버튼을 눌러 증가시키면 1H 이 된다. 1H 일 때, D 버튼을 눌러 감소시키면 24H 이 된다.</p> <p>E5. minute값이 59 일 때, B 버튼을 눌러 증가시키면 0 이 된다. 0 일 때, D 버튼을 눌러 감소시키면 59 이 된다.</p> <p>E6. second값이 59 일 때, B 버튼을 눌러 증가시키면 0 이 된다. 0 일 때, D 버튼을 눌러 감소시키면 59 이 된다.</p>

Use Case	2. Change mode
Actor	User
Type	Evident
Pre requisites	currentState 값이 0,8,12,19,25,26 이어야 한다.
Typical courses of events	<p>(A) : Actor, (S) : System</p> <ol style="list-style-type: none"> 1. (A) User가 C 버튼을 누른다. 2. (S) reqChangeMode()를 호출한다. <ol style="list-style-type: none"> 2-1. (S) changeMode(currentState)를 호출한다. 2. (S) display(selectedSw[i+1])을 호출한다.(i는 현재 선택된 모드의 인덱스이다) <div style="display: flex; justify-content: space-between; margin-top: 20px;"> <div style="width: 45%;"> <ol style="list-style-type: none"> 2-1. Timekeeping (S) display()를 호출한다. </div> <div style="width: 45%;"> <ol style="list-style-type: none"> 2-2 Stopwatch (S) stopwatchTime 변수값을 확인한다. (S) display()를 호출한다. </div> </div>

Typical courses of events

2-3 Timer

(S) timerTime 변수값을 확인한다.
(S) display()을 호출한다.

2-4 Alarm

(S) 알람 목록에 알람이 저장되어 있는지 확인한다.
(S) display()을 호출한다.

2-5 World time

(S) display()을 호출한다.

2-6 Brightness Control

(S) brightness, brightLevel 변수값을 확인한다.
(S) display()을 호출한다.

3. (A) User가 B 버튼을 누른다.

4. (S) reqChangeSW()를 호출한다.

Alternative courses of events

N/A

Exceptional courses of events

E1. selectedSw[]의 인덱스 범위를 초과하게 되면, display(selectedSw[0])를 호출한다.

E2. 저장되어 있는 알람이 없을 때, 알람 모드로 진입 시, 1. --- 를 출력한다.

Use Case	3. Stop ringing
Actor	User
Type	Evident
Pre requisites	Ring onOff 변수값이 true여야한다.
Typical courses of events	<p>(A) : Actor, (S) : System</p> <ol style="list-style-type: none"> 1. (A) : ring이 울릴 때, User는 아무 버튼(A, B, C, D 버튼)이나 누른다. 2. (S) : reqStopRinging()을 호출한다. 2. (S) : User의 요청이 들어오거나 3초가 지나면 onOff값을 false로 변경하여 ring을 멈춘다.
Alternative courses of events	A1. ring이 울린지 3초가 지났을 때, onOff값을 false로 변경하고 자동적으로 ring을 멈춘다.
Exceptional courses of events	N/A

Use Case	4. Start stopwatch
Actor	User
Type	Evident
Pre requisites	1. currentState의 값이 8이어야 하며, Stopwatch의 onOff 변수가 false 상태이어야 한다.
Typical courses of events	<p>(A) : Actor, (S) : System</p> <p>1. (A) : User가 B버튼을 누른다.</p> <p>(S) : reqStartStopwatch()를호출한다.</p> <p>(S) : startStopwatch()를 호출한다.</p> <p>2. (S) : display를 보여준다.</p>
Alternative courses of events	N/A
Exceptional courses of events	N/A

Use Case	5. Stop stopwatch
Actor	User
Type	Evident
Pre requisites	1. currentState의 값이 9이어야 하며, Stopwatch의 onOff 변수가 true 상태이어야 한다.
Typical courses of events	<p>(A) : Actor, (S) : System</p> <p>1. (A) User가 B 버튼을 누른다.</p> <p>(S) reqStopStopwatch()를 호출한다.</p> <p>(S) stopStopwatch()를 호출한다.</p> <p>2. (S) display를 호출한다.</p>
Alternative courses of events	N/A
Exceptional courses of events	N/A

Use Case	6. Reset stopwatch
Actor	User
Type	Evident
Pre requisites	<ol style="list-style-type: none"> 1. currentState의 값이 10이어야 한다. 2. Stopwatch의 onOff 변수가 false 상태이어야 한다.
Typical courses of events	<p>(A) : Actor, (S) : System</p> <ol style="list-style-type: none"> 1. (A) User가 D 버튼을 누른다. 2. (S) reqResetStopwatch()를 호출한다. 3. (S) resetStopwatch()를 호출한다. 4. (S) display을 호출한다.
Alternative courses of event	N/A
Exceptional courses of events	E1.currentState가 이외의 값이면 D(reset) 버튼을 눌러도 초기화되지 않는다.

Use Case	7. Lap stopwatch
Actor	User
Type	Evident
Pre requisites	<ol style="list-style-type: none"> 1. currentState의 값이 9이어야 한다. 2. Stopwatch의 onOff 변수가 true 상태이어야 한다.
Typical courses of events	<p>(A) : Actor, (S) : System</p> <ol style="list-style-type: none"> 1. (A) User가 A 버튼을 누른다. 2. (S) reqLapTime()을 호출한다. 3. (S) lapTime()을 호출한다. 4. (S) display을 호출한다.
Alternative courses of events	N/A
Exceptional courses of events	E1. stopwatchTime은 계속해서 측정된다.

Use Case	8. Select alarm num
Actor	User
Type	Evident
Pre requisites	1. currentState의 값이 12 -15이어야 한다.
Typical courses of events	(A) : Actor, (S) : System 1. (A) User가 B버튼을 누른다. 2. (S) reqSelectAlarmNum()을 호출한다. 3. (S) getAlarmTime(currentState)을 호출한다. 3. (S) display을 호출한다.
Alternative courses of events	A1. 원하는 알람번호가 나올때까지 반복한다.
Exceptional courses of events	N/A

Use Case	9. Remove alarm num
Actor	User
Type	Evident
Pre requisites	1. currentState의 값이 12-15이어야 한다.
Typical courses of events	(A) : Actor, (S) : System 1. (A) User가 D 버튼을 누른다. 2. (S) reqRemoveAlarmNum()을 호출한다. 3. (S) removeAlarmNum(currentState: int)를 호출한다. 4. (S) display를 호출한다.
Alternative courses of events	A1. alarmArray 내부의 값이 비어있을 경우, AlarmIndicator를 false로 업데이트한다.
Exceptional courses of events	N/A

Use Case	10. Set Alarm Time
Actor	User
Type	Evident
Pre-Requisites	1. currentState의 값이 12-18이어야 한다.
Typical courses of events	<p>(A): Actor, (S): System</p> <ol style="list-style-type: none"> 1. (A) User가 A 버튼을 누른다. 2. (S) reqSetAlarmTime(button: int)을 호출한다. <ol style="list-style-type: none"> 2.1 (S) enterSetSection(current: int)을 호출한다. <ol style="list-style-type: none"> 3.1.1 (A) User가 B 버튼을 누른다. 3.1.2 (S) reqChangeValue(button:int)을 호출한다. 3.1.3 (S) changeValue(button: int)을 호출한다. 3.2.1 (A) User가 D 버튼을 누른다. 3.2.2 (S) reqChangeValue(button:int)을 호출한다. 3.2.3 (S) changeValue(button: int)을 호출한다. 4. (A) User가 C 버튼을 누른다 5. (S) 새로운 값이 alarmArray()에 저장된다.

Alternative courses of events	N/A
Exceptional courses of events	E1. 각 영역의 값이 최대값보다 커질 경우 0으로 0보다 작아질 경우는 최대값으로 한다. E2. 선택 가능한 영역에서 A버튼을 한번 더 누르면 다시 초기 영역으로 돌아온다. E3. alarmArray[i]의 값이 설정이 안됐을 경우 초기 설정값은 -시 --분 이다.

Use Case	11. Turn on Alarm
Actor	System
Type	Hidden
Pre-Requisites	N/A
Typical courses of events	(S): System 1. (S) controlAlarmIndicator()를 호출한다. 2. (S) checkAlarmArray()를 호출한다.
Alternative courses of events	N/A
Exceptional courses of events	N/A

Use Case	12.Turn off Alarm
Actor	System
Type	Hidden
Pre-Requisites	N/A
Typical courses of events	(S): System 1. (S) controlAlarmIndicator()를 호출한다. 2. (S) checkAlarmArray()를 호출한다.
Alternative courses of events	N/A
Exceptional courses of events	N/A

Use Case	13. Set timer time
Actor	User
Type	Evident
Pre-Requisites	<ol style="list-style-type: none">1. currentState의 값이 19-22이어야 한다.2. Timer 개체의 onOff 값이 false이어야 한다.
Typical courses of events	<ol style="list-style-type: none">1. (A) User가 A 버튼을 누른다.2. (S) reqSetTimerTime(button:int)을 호출한다.3. (S) enterSetSection(currentState:int)을 호출한다.4. (A) User가 B or D버튼을 누른다.5. (S) reqChangeValue(button:int)을 호출한다.6. (S) changeValue(currentState:int)을 호출한다.7. (S) User가 C 버튼을 누른다.8. (S) timerTime을 저장한다.

Alternative courses of events	N/A
Exceptional courses of events	E1. second의 최대값(59)에서 B 버튼을 누르면 변수값을 0으로 변경한다. E2. minute의 최대값(59)에서 B 버튼을 누르면 변수값을 0으로 변경한다. E3. hour의 최대값(23)에서 B 버튼을 누르면 변수값을 0으로 변경한다.

Use Case	14. Start timer
Actor	User
Type	Evident
Pre-Requisites	<ol style="list-style-type: none"> 1. currentMode의 값이 19이어야 한다. 2. Timer 개체의 onOff 값이 false이어야 한다.
Typical courses of events	<p>(A): Actor, (S): System</p> <ol style="list-style-type: none"> 1. (A) User가 B버튼을 누른다. 2. (S) reqStartTimer()을 호출한다. 3. (S) startTimer()을 호출한다. 5. (S) display를 호출한다.
Alternative courses of events	A1. Timer가 start 된 상태에서 Mode를 전환해도 Timer는 돌아가고 있어야한다.
Exceptional courses of events	E.1 각 영역의 값이 0이 될 경우 감소를 시키지 않는다.

Use Case	15. Stop timer
Actor	User
Type	Evident
Pre-Requisites	1. currentMode의 값이 23이어야 한다. 2. Timer 객체의 onOff 값이 true이어야 한다.
Typical courses of events	(A): Actor, (S): System 1. (A) User가 B 버튼을 누른다. 2. (S) reqStopTimer()을 호출한다. 3. (S) stopTimer()을 호출한다. 4. (S) display를 호출한다.
Alternative courses of events	N/A
Exceptional courses of events	N/A

Use Case	16. Reset timer
Actor	User
Type	Evident
Pre-Requisites	<ol style="list-style-type: none"> 1. currentMode의 값이 24이어야 한다. 2. Timer 개체의 onOff 값이 false이어야 한다.
Typical courses of events	<p>(A): Actor, (S): System</p> <ol style="list-style-type: none"> 1. (A) User가 D 버튼을 누른다. 2. (S) reqResetTimer()을 호출한다. 3. (S) resetTimer()을 호출한다. 4. (S) display를 호출한다.
Alternative courses of events	N/A
Exceptional courses of events	N/A

Use Case	17. Ringing
Actor	System
Type	Hidden
Pre-Requisites	N/A
Typical courses of events	1. (S) checkAlarm(), checkTimer()을 호출한다. 2. (S) Ring 객체는 onOff 값에 따라 ringing()을 호출한다.
Alternative courses of events	A1. (S) System은 Alarm, Timer 모드가 아닌 경우에서도 Ringing이 호출된다.
Exceptional courses of events	E1. Ring의 onOff 변수가 true일 때, 호출된 ringing()은 무시한다.

Use case	18. Change world
Actor	User
Type	Evident
Pre - requisites	1. currentState의 값이 25이어야 한다.
Typical courses of events	<p>1.1 (A) : User가 B 버튼을 누른다.</p> <p>1.1.1 (S) : reqChangeWorld() 를 호출한다.</p> <p>1.1.2 (S) : changeIndex()를 호출한다.</p> <p>1.2 (A) : User가 D 버튼을 누른다.</p> <p>1.2.1 (S) : reqChangeWorld() 를 호출한다.</p> <p>1.2.2 (S) : changeIndex()를 호출한다.</p>
Alternative courses of events	N/A
Exceptional courses of events	N/A

Use case	19. Turn on brightness control
Actor	User
Type	Evident
Pre - requisites	1. currentState의 값이 26이어야한다.
Typical courses of events	<ol style="list-style-type: none"> 1. (A) User 가 D 버튼을 누른다. 2. (S) reqTurnOnBC() 를 호출한다. 3. (S) checkBC() 를 호출하여 brightness 를 확인한다. 4. (S) switchBC() 를 호출하여 brightness 에 true 를 저장한다. 5. (S) daylong(currentTime)을 호출하여 현재 밝기를 적용한다. 6. (S) display의 밝기를 조절한다.
Alternative courses of events	
Exceptional courses of events	E1. Brightness control (BC) 기능이 켜진상태에서는 동작하지 않는다.

Use case	20. Turn off brightness control
Actor	User
Type	Evident
Pre - requisites	1. currentState의 값이 26이어야한다.
Typical courses of events	<ol style="list-style-type: none"> 1. (A) User 가 D 버튼을 누른다 . 2. (S) reqTurnOffBC() 를 호출한다. 3. (S) checkBC()를 호출하여 brightness 를 확인한다. 4. (S) switchBC() 를 호출하여 brightness 에 false 를 저장한다. 5. (S) initializeBC() 를 호출하여 brightLevel을 '0' 으로 조정한다. 6. (S) display를 밝기를 조절한다.
Alternative courses of events	N/A
Exceptional courses of events	E1.Brightness control (BC) 기능이 켜진 상태에서만 동작한다.

Use case	21. Control brightness
Actor	User
Type	Evident
Pre - requisites	<ol style="list-style-type: none"> 1. currentState의 값이 27이어야한다. 2. brightness 변수에 저장된 값이 true이어야한다.
Typical courses of events	<ol style="list-style-type: none"> 1. (A) User 가 B 버튼을 누른다 . <ol style="list-style-type: none"> 1.1 (S) reqControlBC() 를 호출한다. 1.2 (S) changeBClevel() 을 호출한다. 1.3 (S) display 밝기를 조절한다. 2. (A) User가 C 버튼을 누른다. <ol style="list-style-type: none"> 2.1 (S) brightLevel 을 저장한다.
Alternative courses of events	밝기 level은 3단계가 버튼 하나로 순환한다.
Exceptional courses of events	N/A

Use case	22. Change brightness
Actor	User
Type	Hidden
Pre - requisites	1. brightness 변수에 저장된 값이 true여야한다.
Typical courses of events	1. (S) 현재 시간의 minute과 second 값이 0일때(매시 정각) daylong(currentTime)을 호출한다. 2. (S) display의 brightLevel 을 조정한다.
Alternative courses of events	N/A
Exceptional courses of events	N/A

Use case	23. Change SW
Actor	User
Type	Evident
Pre - requisites	currentState가 0번이어야 한다.
Typical courses of events	<ol style="list-style-type: none"> 1. (A) User가 D 버튼을 누른다. 2. (S) reqChangeSW(button : int)를 호출한다. 3. (S) enterChangeSW() 를 호출한다. 4.1.1 (A) User가 B 버튼을 누른다. 4.1.2 (S) reqChangeSW(button : int)를 호출한다. 4.1.3 (S) changeSW를 호출한다.(timekeeping 제외) 4.1.4 (S) display를 호출한다. 4.2 (A) User가 A 버튼을 누른다. 4.2.1 (S) reqChangeSW(button : int) 를 호출한다. 4.2.2 (S) selectSW()를 호출한다 4.2.3 (S) display를 호출한다. 5. (A) User가 D 버튼을 누른다. 6. (S) TimeKeeping 모드로 돌아간다.
Alternative courses of events	N/A
Exceptional courses of events	E1. Timekeeping은 Default 기능으로 ChangeSW시 제외할 수 없다.

Activity 2042 : Design UI

※ Button Map

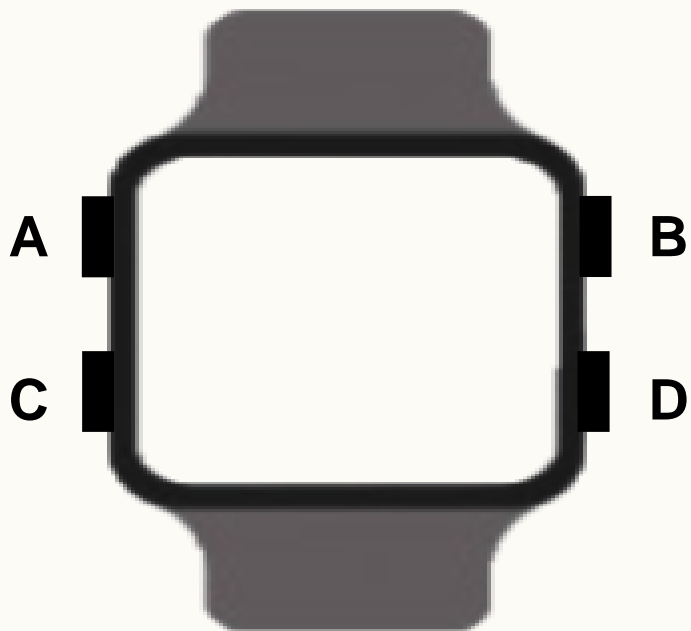

※ Mode

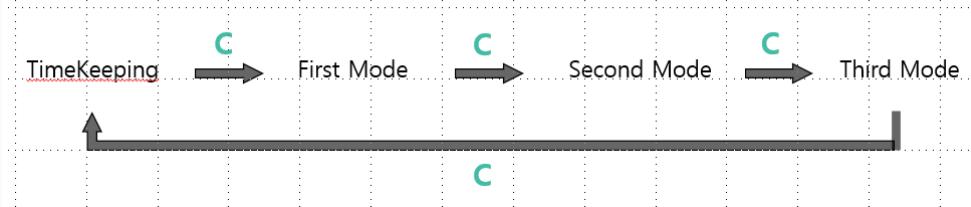

※ TimeKeeping

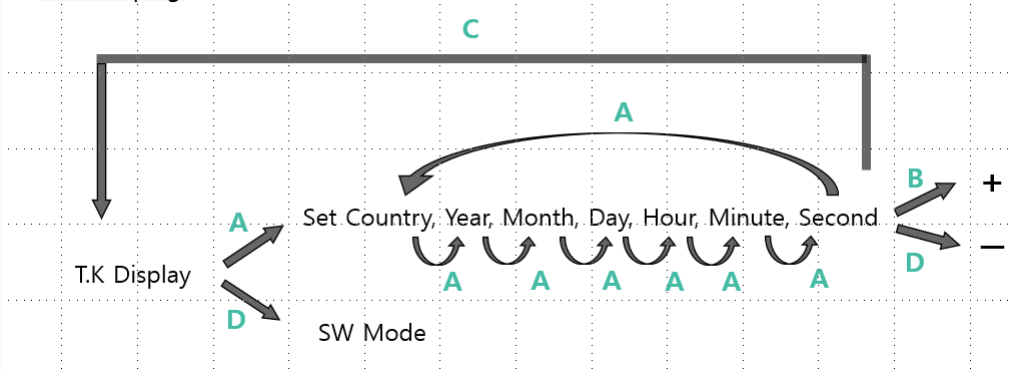

※ Stopwatch

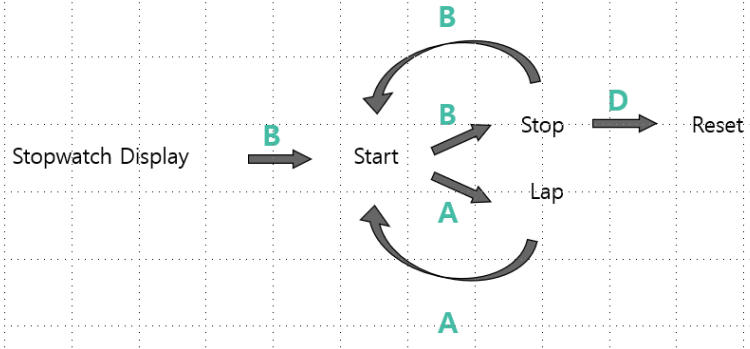

※ Timer

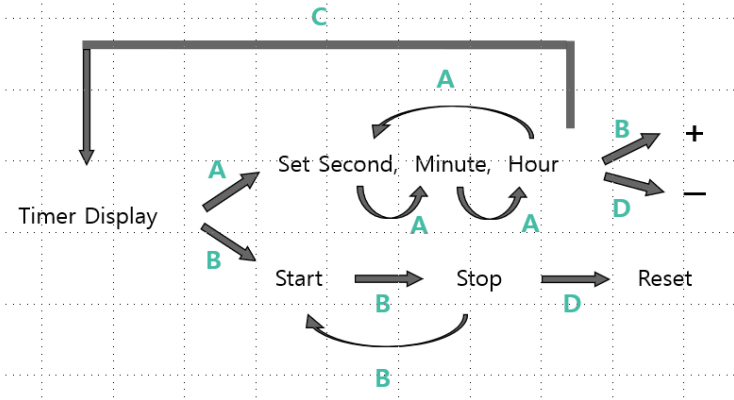

※ Alarm

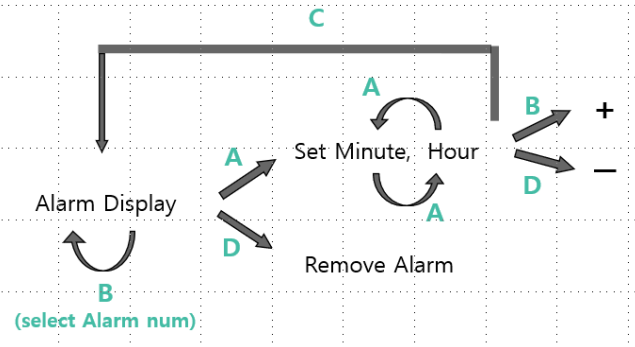

※ Brightness Control

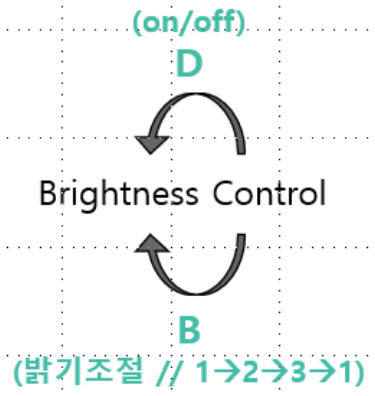

※ World time

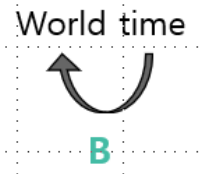

※ SW

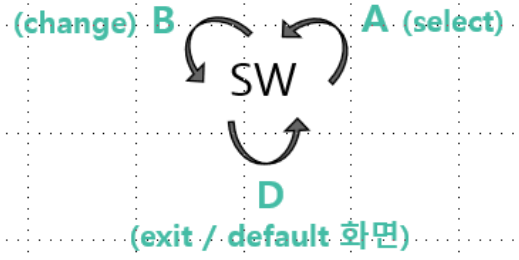

Timekeeping

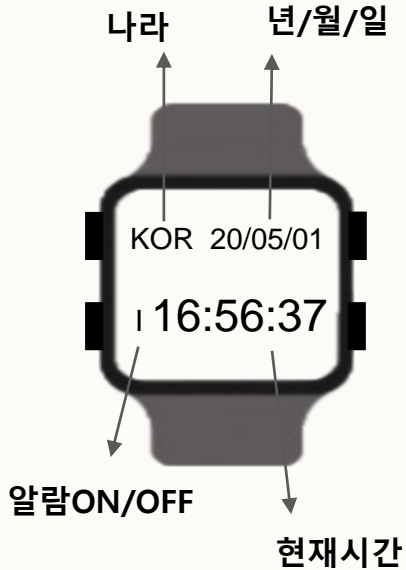

<Timekeeping>
SetTime_second



Stopwatch



<Stopwatch>
LapTime



Timer

모드명 현재시간



Timer Time

<Timer>
SetTimerTime_hour



Alarm

모드명 현재시간



알람 번호

Alarm Time

<Alarm>
selectAlarmNum



<Brightness Control>
MODE ON : LV.1

<Brightness Control>
MODE ON : LV.2

<Brightness Control>
MODE ON : LV.3

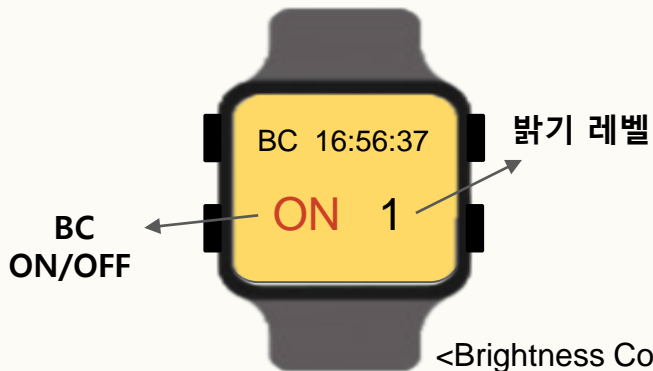

<Brightness Control>
MODE ON:
특정 시간 이후

<Brightness Control>
MODE OFF:
LV.0

Brightness Control



- 0 : timekeeping 기본
- 1 : world
- 2 : year
- 3 : month
- 4 : day
- 5 : Hour
- 6 : minute
- 7 : second
- 8 : stopwatch 기본
- 9 : start
- 10 : stop
- 11 : lap
- 12 : alarm 기본 1
- 13 : alarm 기본 2
- 14 : alarm 기본 3
- 15 : alarm 기본 4
- 16 : hour
- 17 : minute
- 18 : second
- 19 : timer
- 20 : timer Hour
- 21 : minute
- 22 : Second
- 23 start timer
- 24 stop
- 25 world time
- 26 BC 기본
- 27 BC 수정화면
- 28 change모드 화면

<WorldTime>
Russia



SW



Activity 2043 :
Define Interaction Diagrams

1.

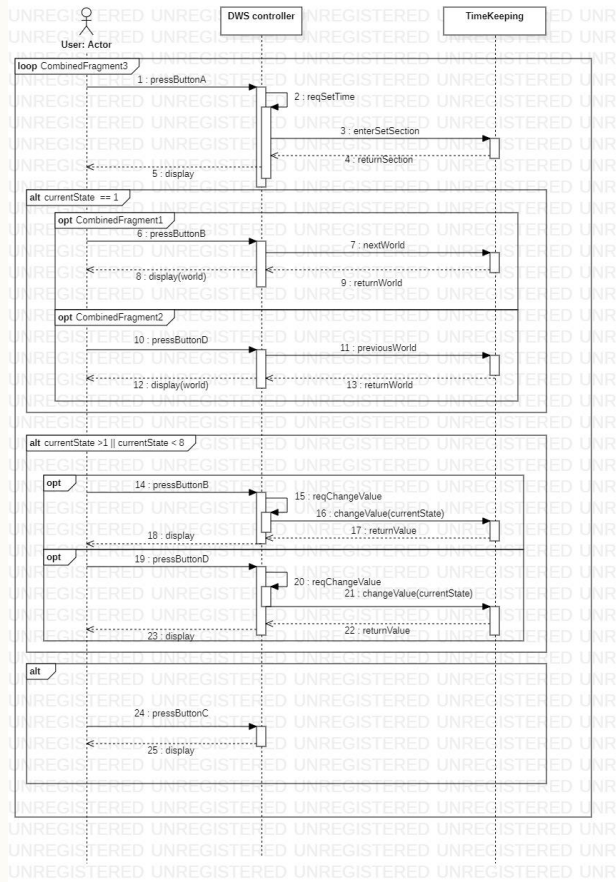

4.

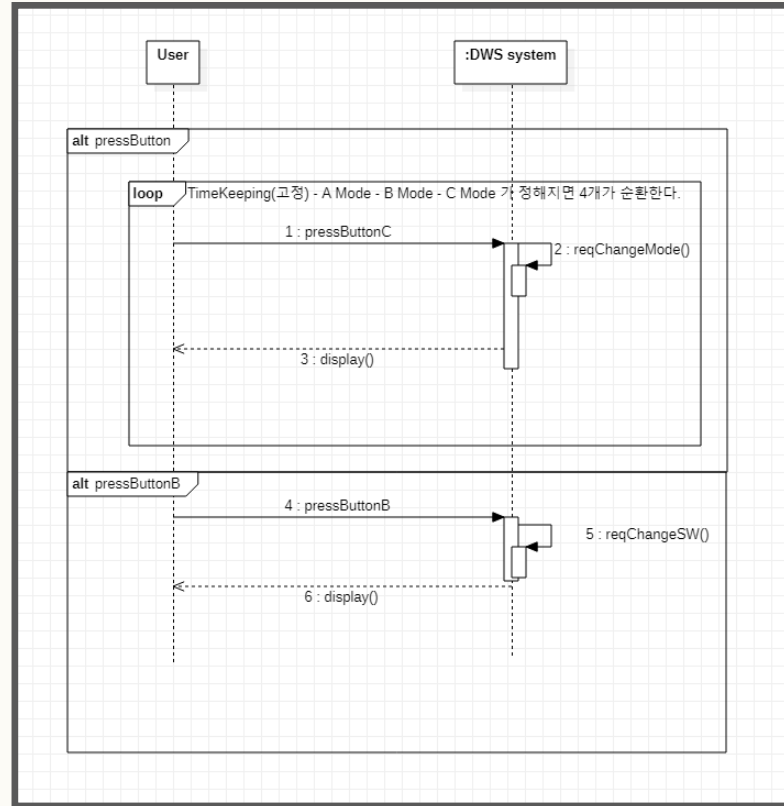

5.

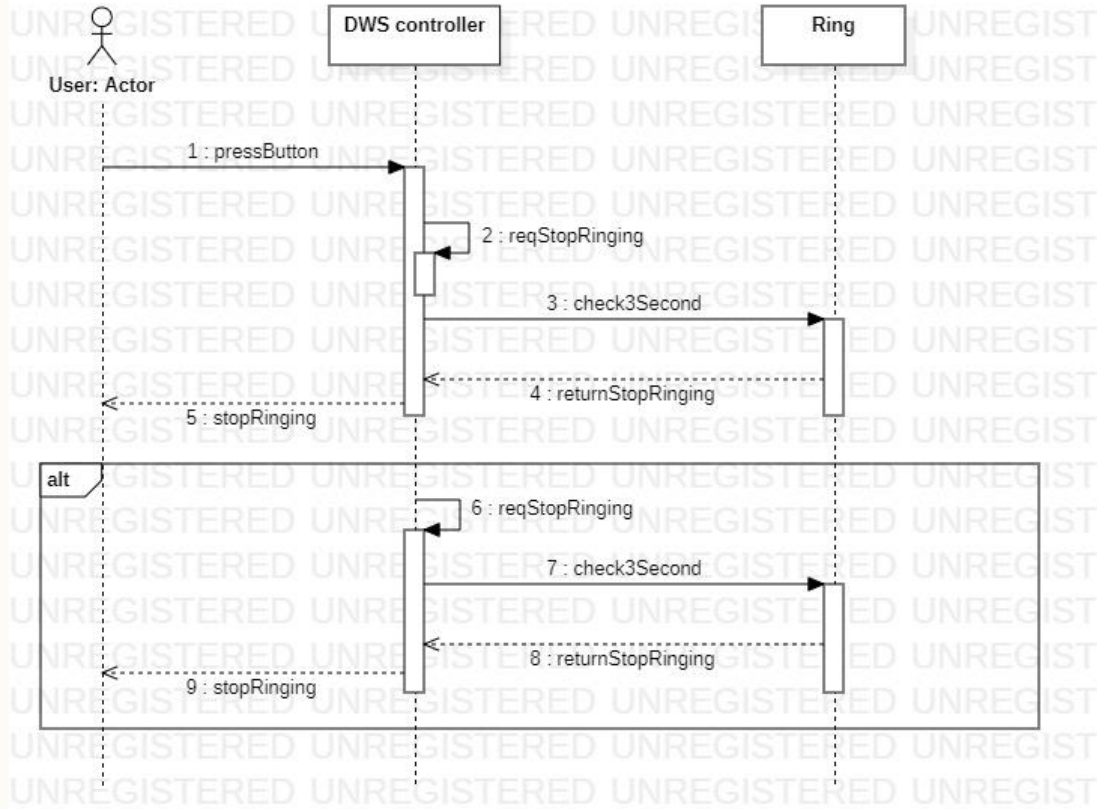

6.

interaction 6.startStopwatch

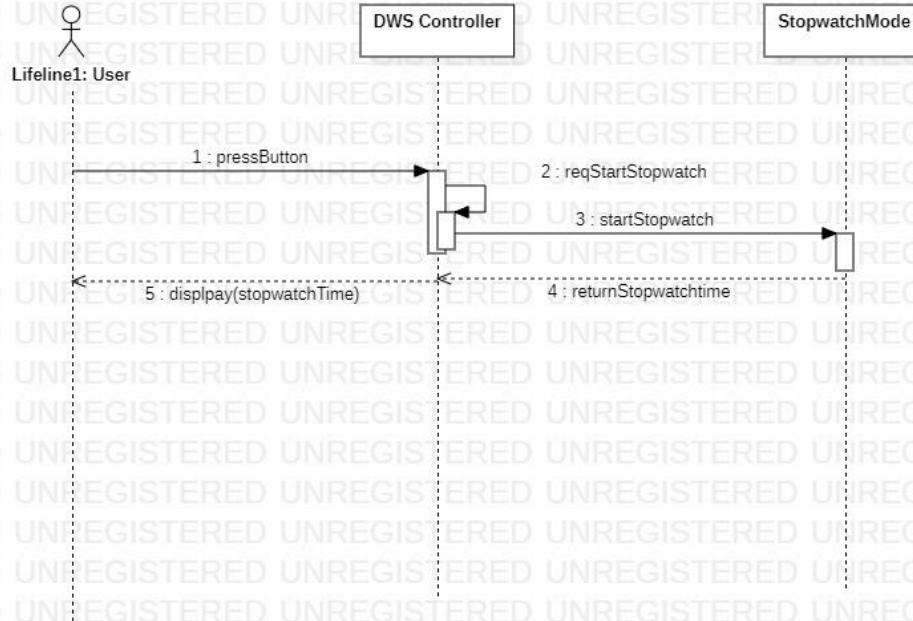

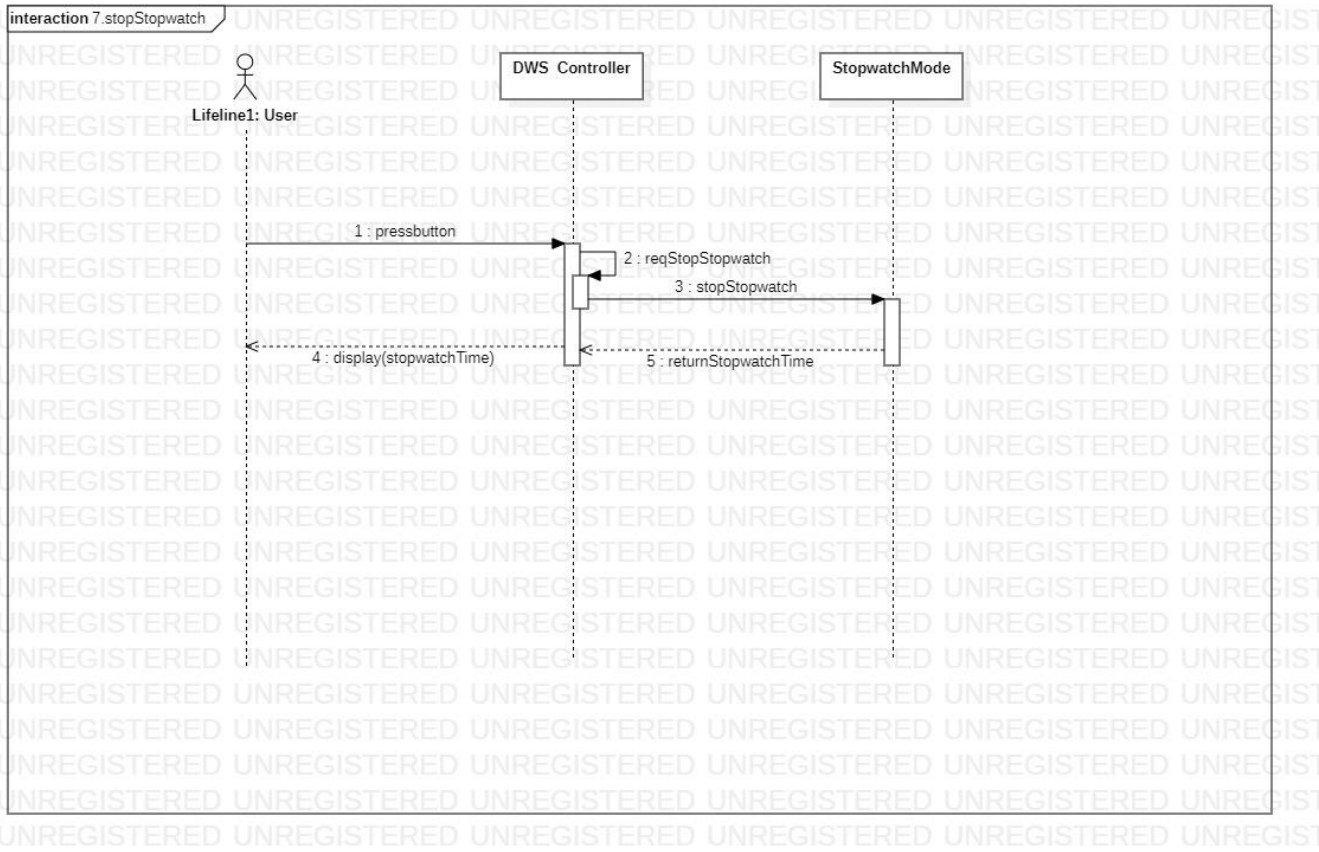

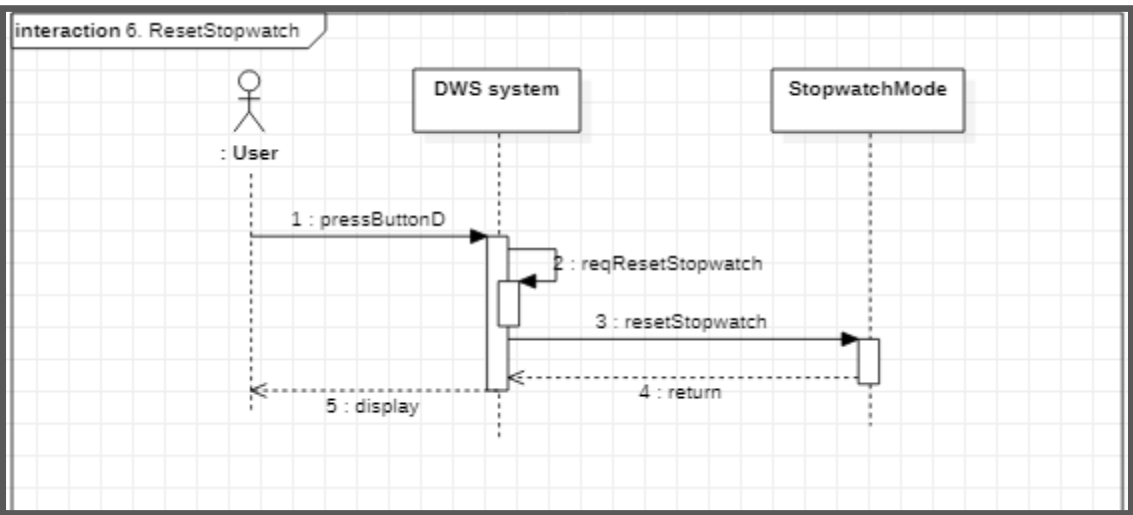

interaction 7. LapStopwatch

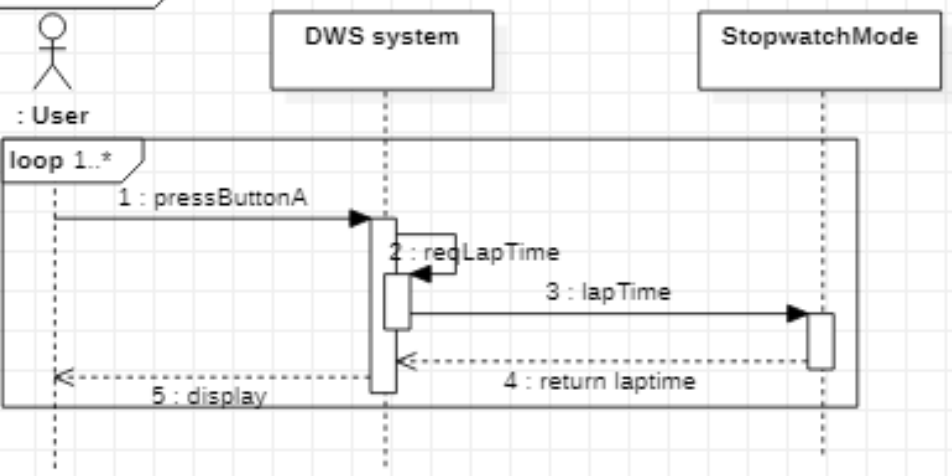

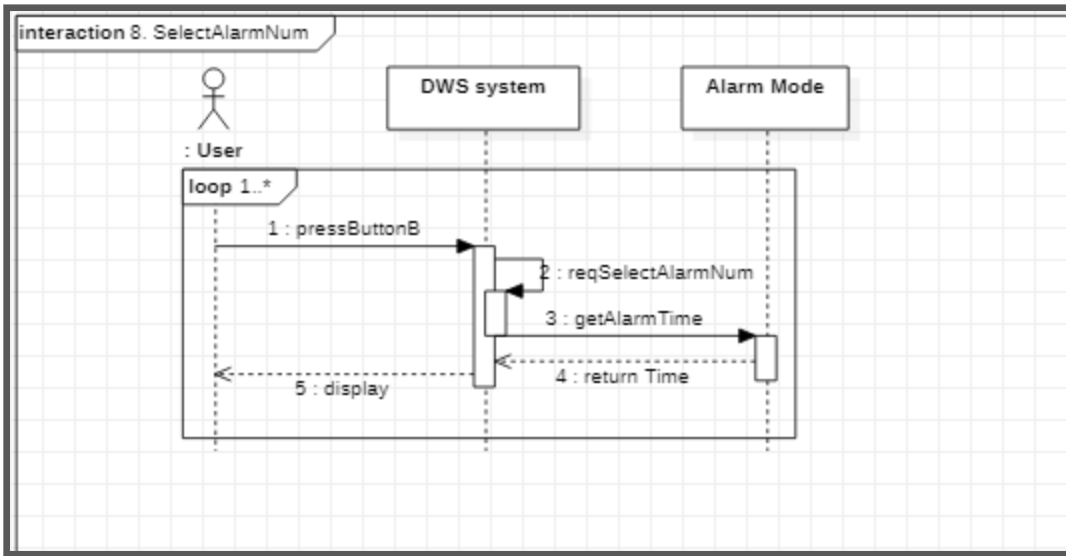

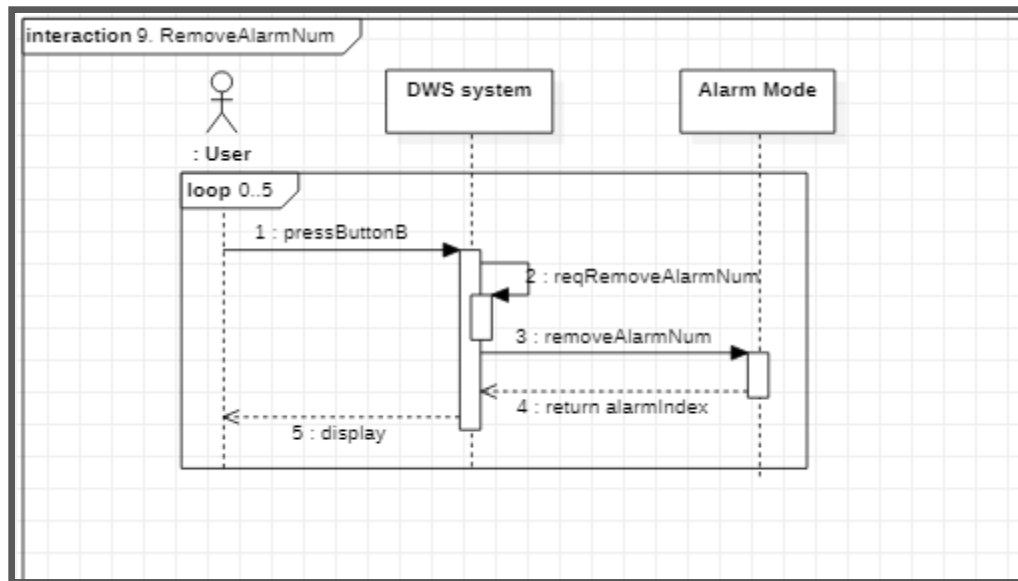

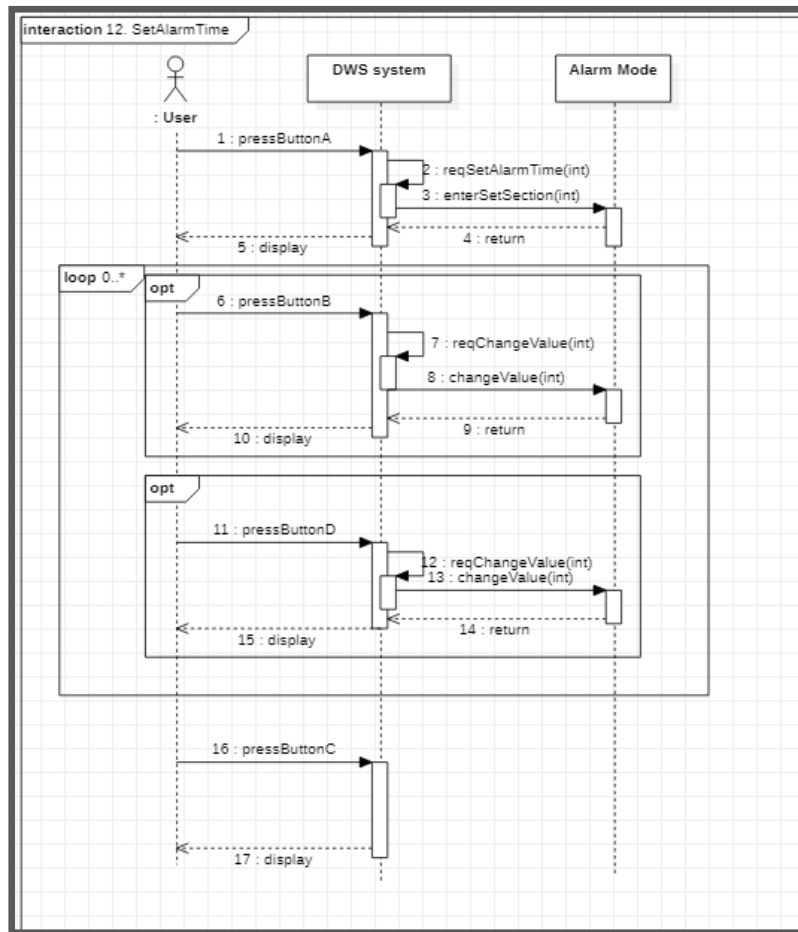

interaction 11. TurnOnAlarm

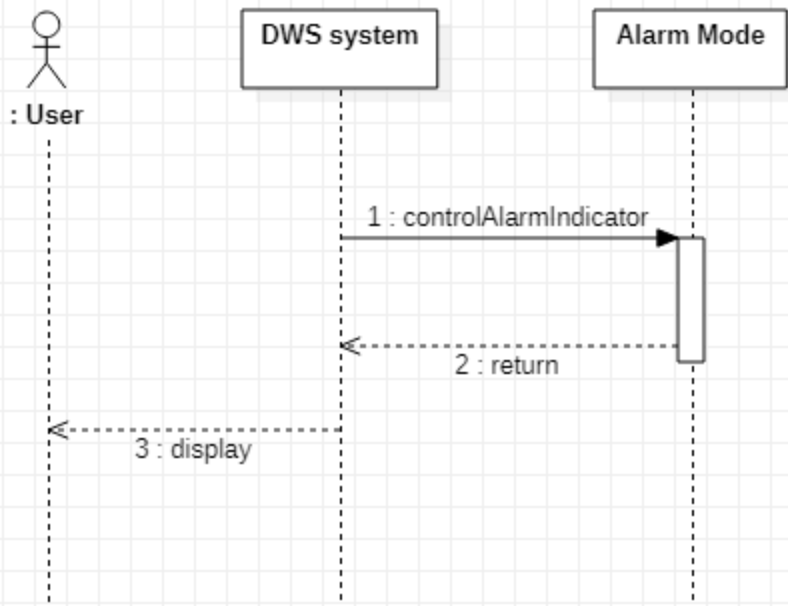

interaction 12. TurnOffAlarm

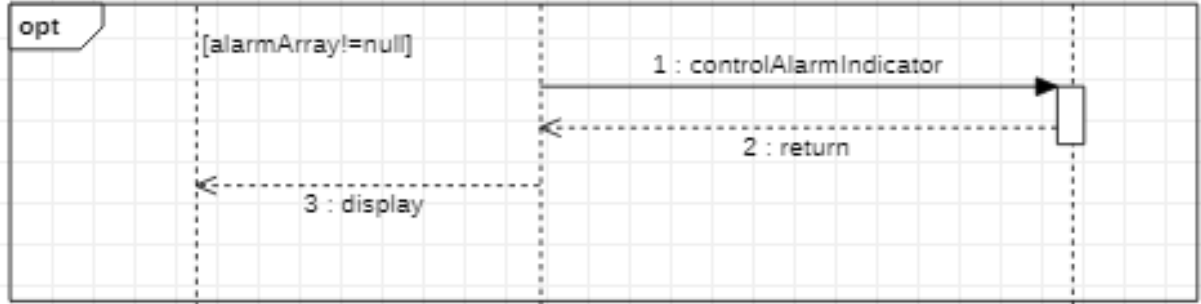
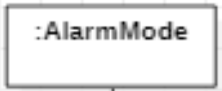
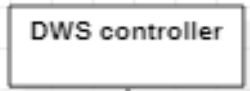

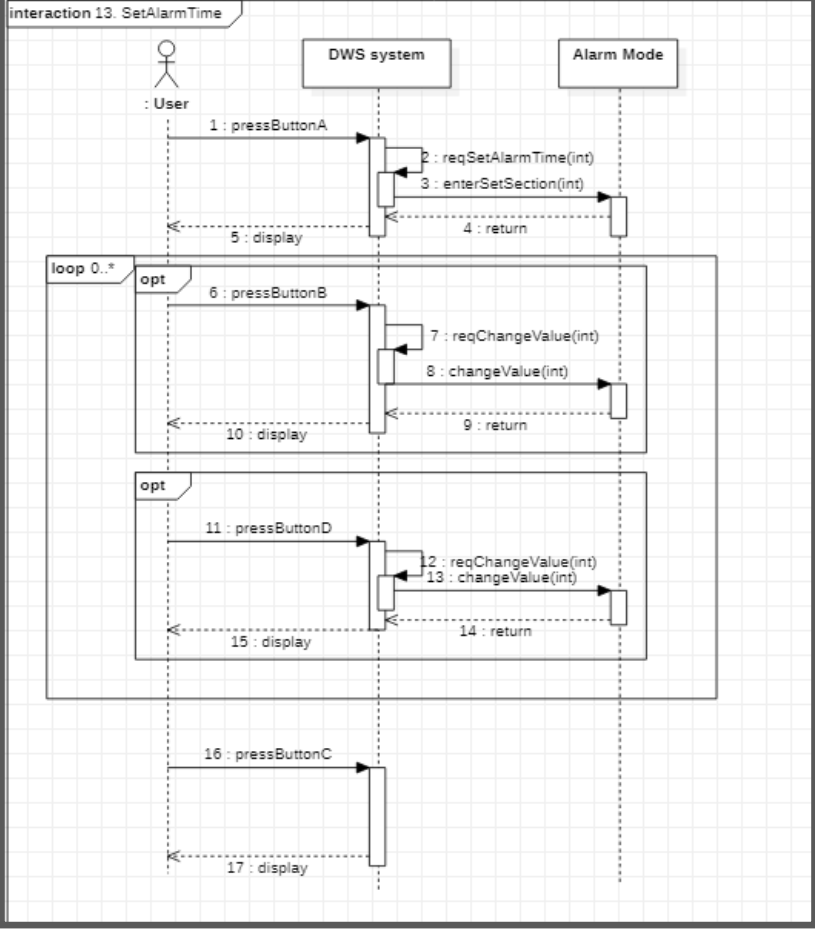

interaction 14.StartTimer

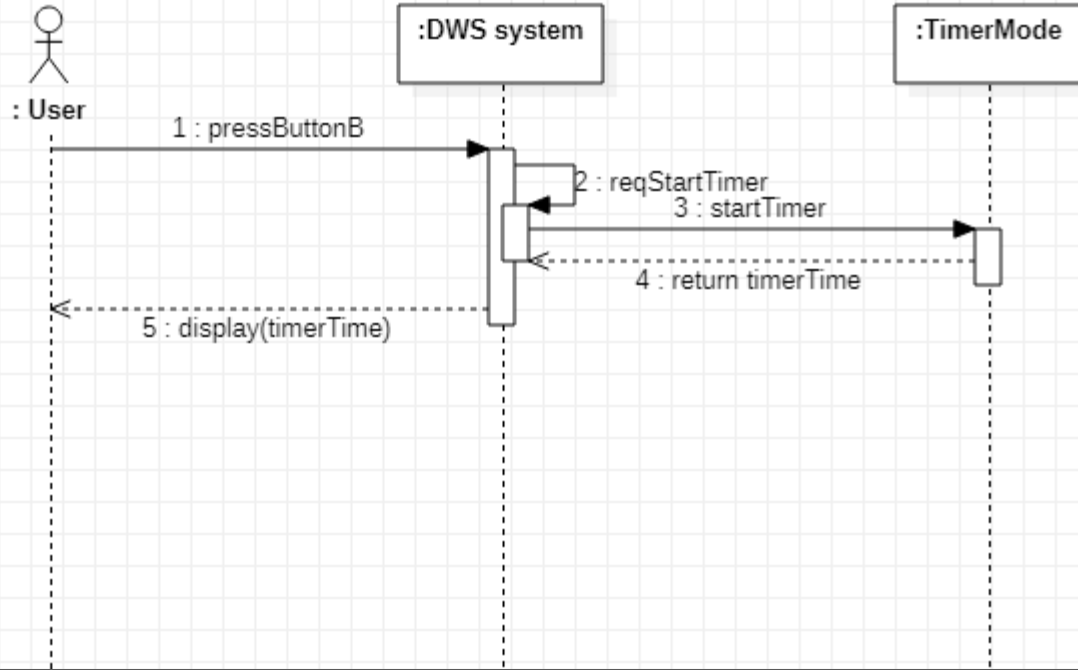

interaction 15. StopTimer

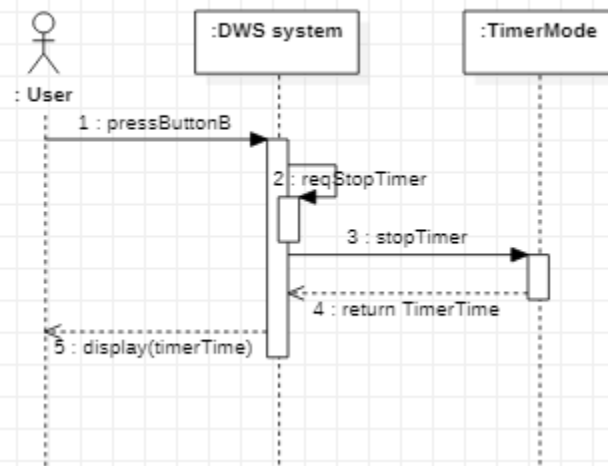

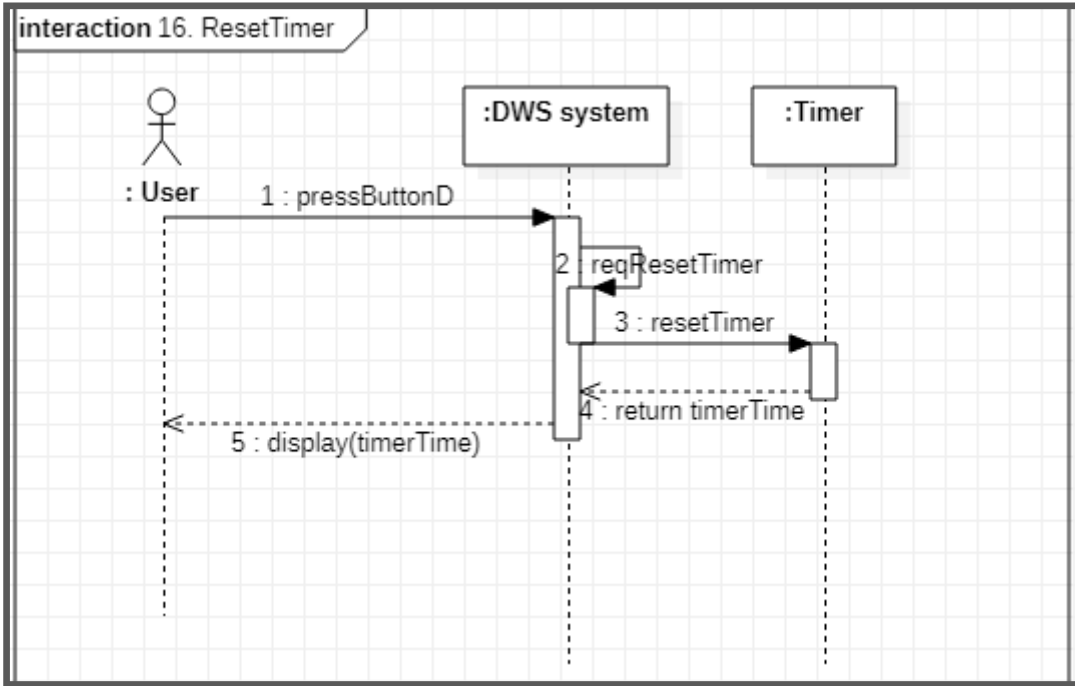

interaction 17. Ringing

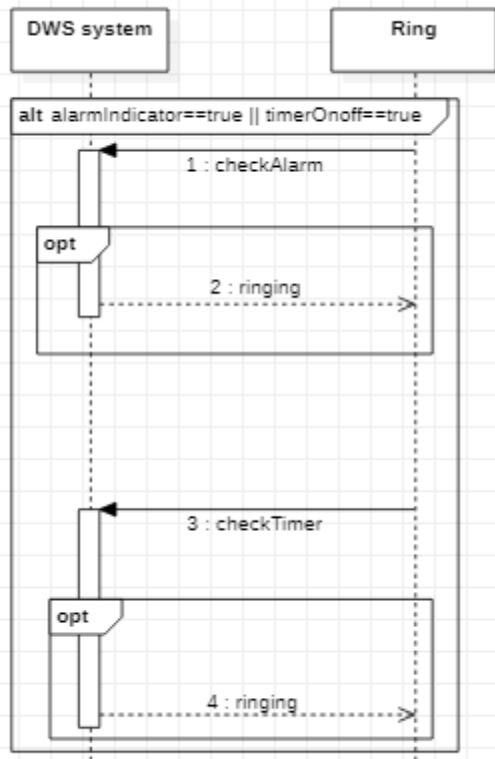

interaction 18. ChangeCountry

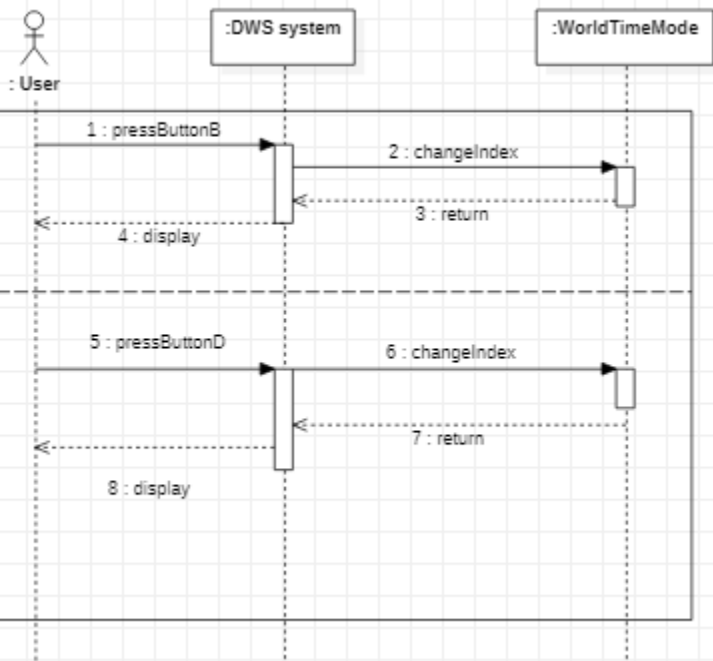

19.

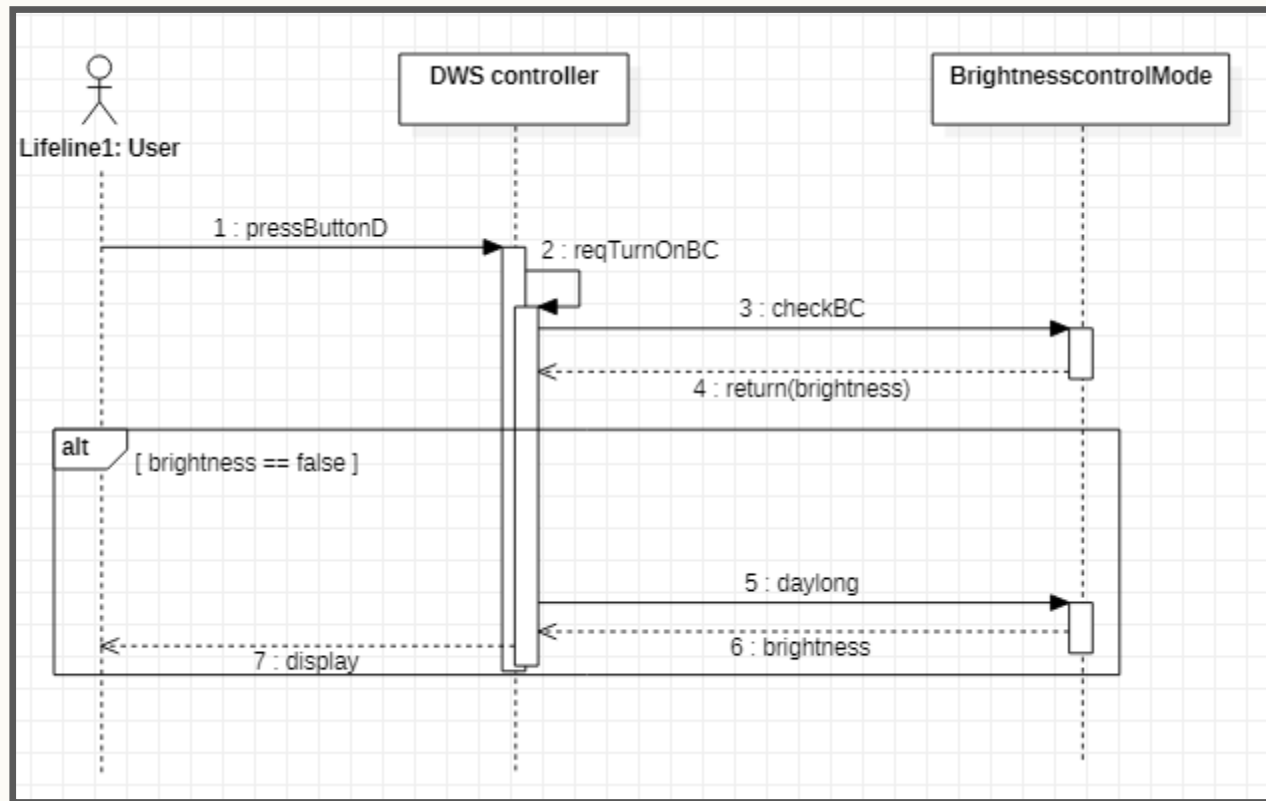

20.

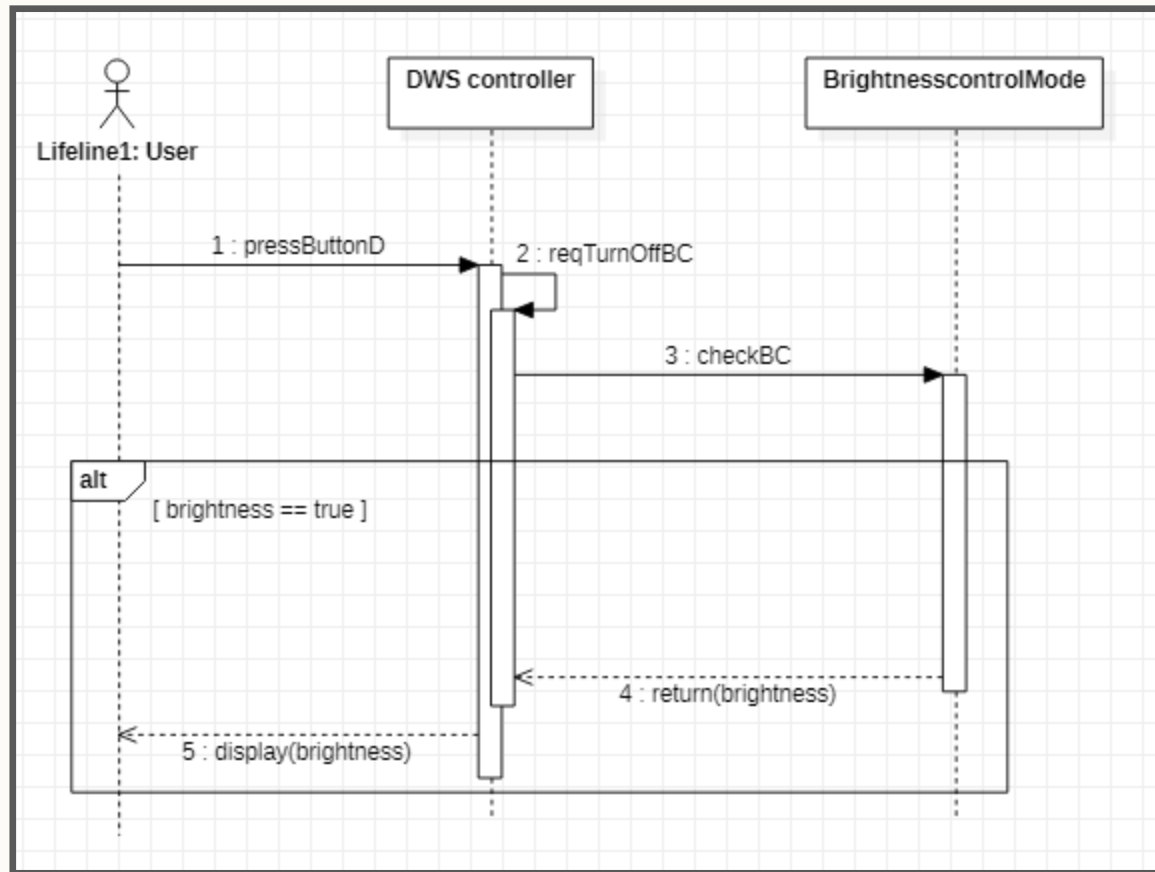

21.

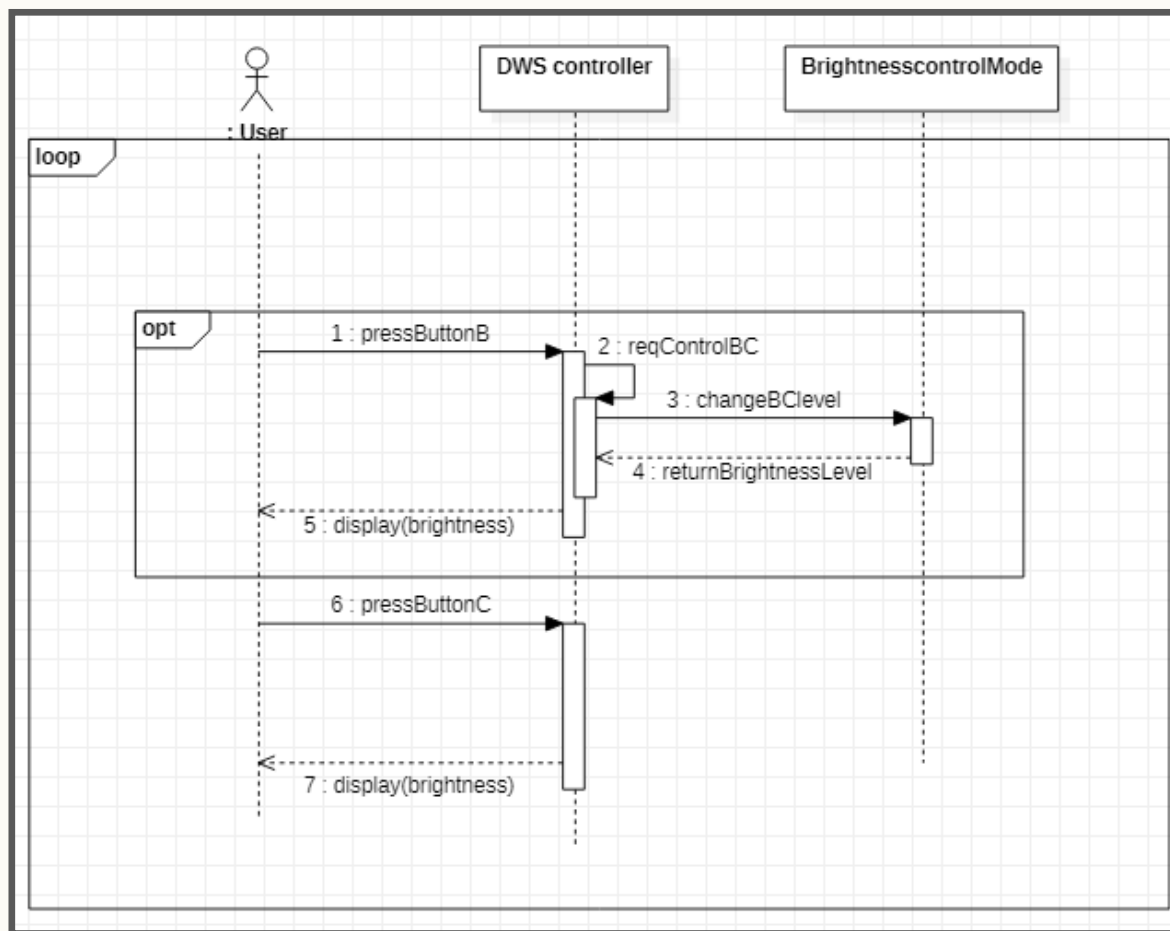

22.

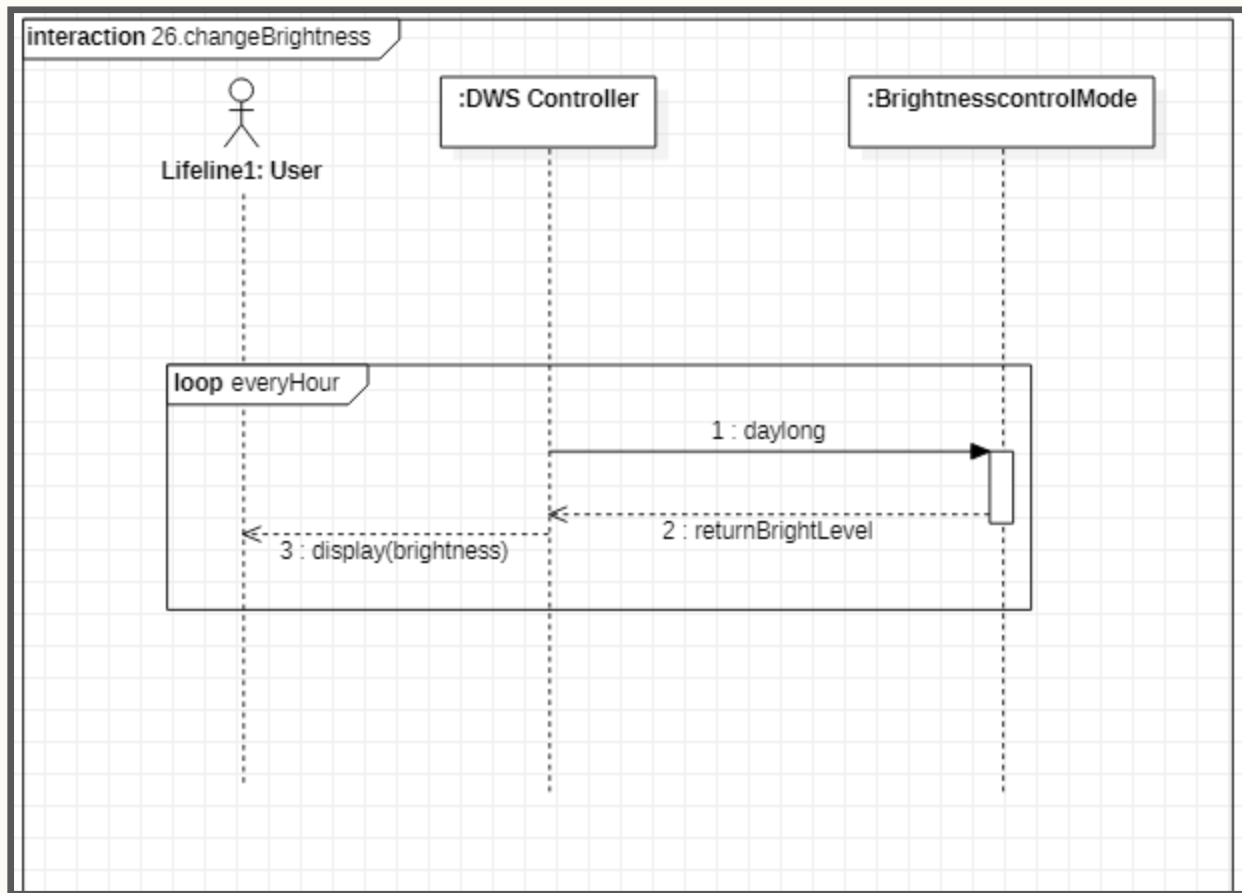

23.

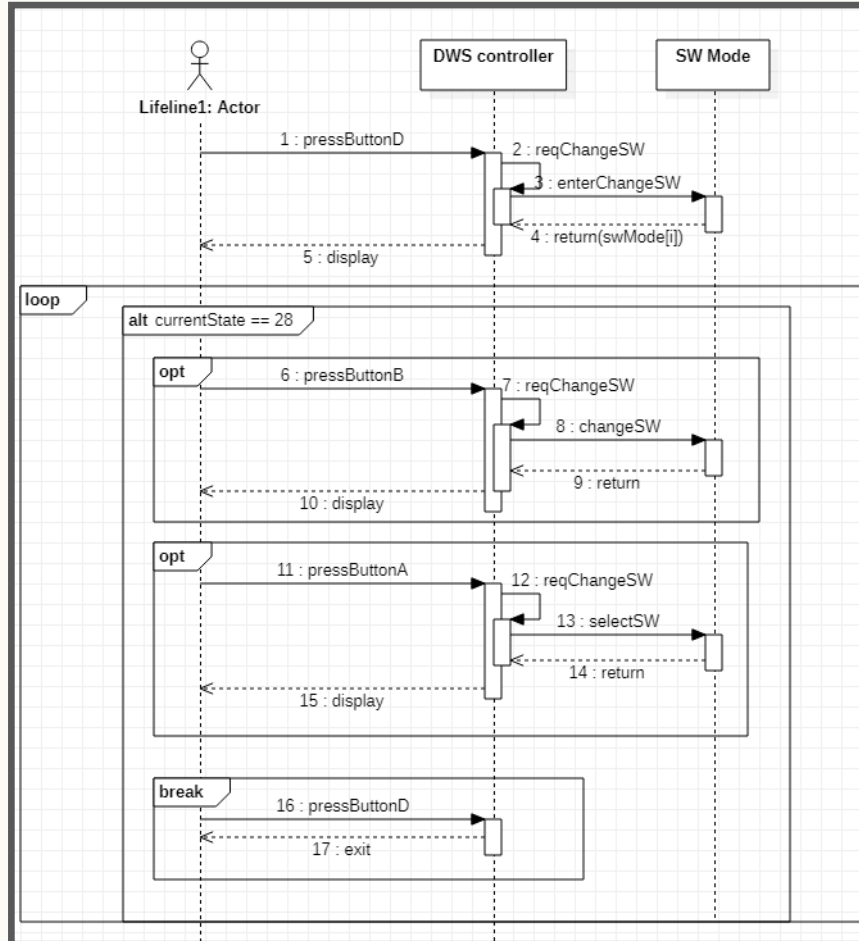

Activity 2044 :
Define Define Class Diagrams

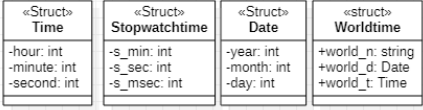
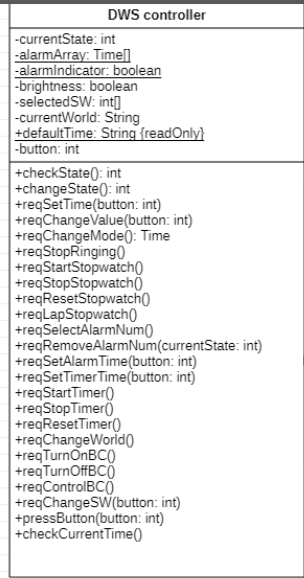

- 0 : timekeeping 기본
1 : world
2 : year
3 : month
4 : day
5 : Hour
6 : minute
7 : second
8 : stopwatch 기본
9 : start
10 : stop
11 : lap
12 : alarm 기본 1
13 : alarm 기본 2
14 : alarm 기본 3
15 : alarm 기본 4
16 : hour
17 : minute
18 : second
19 : timer
20 : timer Hour
21 : minute
22 : Second
23 start timer
24 stop
25 world time
26 BC 기본
27 BC 수정화면
28 change모드 화면

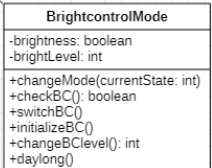
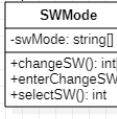
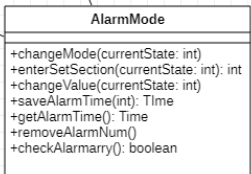
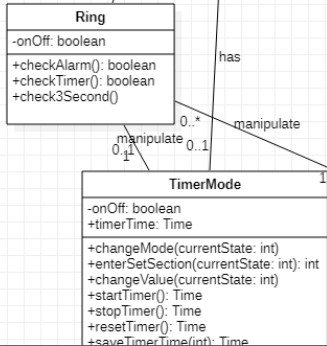

Activity 2047 :
Perform 2040 Traceability Analysis

Essential UseCase	S-Link	SID	Operation in Sequence Diagram	M-Link	MID	Method	Class
Set time	S1, S3, S21	S1	reqSetTime()	M1-3, M5, M6, M7	M1	display() : void	UI
Show current time	S1-19, S22	S2	reqChangeMode()	M1-3, M9, M14, M22, M31, M34, M40	M2	showCurrentTime() : void	
Show current date	S1-19, S22	S3	reqChangeValue(button: int)	M1-3, M8, M21, M32	M3	showCurrentDate() : void	
Change mode	S2, S21	S4	reqStopRinging()	M1-3, M23	M4	ringing () : void	
Stop ringing	S4, S21	S5	reqStartStopwatch()	M1-3, M10, M15	M5	enterSetSection(currentState: int) : int	TimekeepingMode
Start stopwatch	S5, S21	S6	reqStopStopwatch()	M1-3, M11	M6	nextWorld(): void	
Stop stopwatch	S6, S21	S7	reqResetStopwatch()	M1-3, M12	M7	previousWorld() void	
Reset stopwatch	S7, S21	S8	reqLapTime()	M1-3, M13	M8	changeValue(currentState: int) : void	
Lap stopwatch	S8, S21	S9	reqSelectAlarmNum()	M1-3, M16	M9	changeMode(currentState: int) : void	
Select alarm number	S9, S21	S10	reqRemoveAlarmNum()	M1-3, M17	M10	startStopwatch() : void	StopwatchMode
Remove alarm number	S10, S21	S11	reqSetAlarmTime(button : int)	M1-3, M18, M19	M11	stopStopwatch() : void	
Set Alarm Time	S3, S11, S21	S12	reqSetTimerTime(button : int)	M1-3, M26, M27	M12	resetStopwatch() : void	
Turn on alarm		S13	reqStartTimer()	M1-3, M28	M13	lapTime() : StopwatchTime	
Turn off alarm		S14	reqStopTimer()	M1-3, M29	M14	changeMode(currentState: int) : void	
Set timer time	S3, S12, S21	S15	reqResetTimer()	M1-3, M30	M15	callStopwatchTime() : StopwatchTime	
Start timer	S13, S21	S16	reqChangeWorld()	M1-3, M33	M16	getAlarmTime() : Time	AlarmMode
Stop timer	S14, S21	S17	reqTurnOnBC()	M1-3, M35, M36	M17	removeAlarmNum() : void	
Reset timer	S15, S21	S18	reqTurnOffBC()	M1-3, M35, M36, M37	M18	enterSetSection(currentState : int) : int	
Ringing		S19	reqControlBC()	M1-3, M38	M19	saveAlarmTime(alarmIndex : int) : Time	
Change World	S16, S21	S20	reqChangeSW(button: int)	M1, M41, M42, M43	M20	checkAlarmArray() : boolean	
Turn on brightness control	S17, S21	S21	pressButton(button : int)	M1, M20	M21	changeValue(currentState: int) : void	
Turn off brightness control	S18, S21	S22	checkCurrentTime()	M1-3, M39	M22	changeMode(currentState: int) : void	
Control brightness	S19, S21				M23	check3Second() : boolean	Ring
Change brightness	S22				M24	checkAlarm() : boolean	
Change SW	S20, S21				M25	checkTimer() : boolean	
					M26	enterSetSection(currentState : int) : int	TimerMode
					M27	saveTimerTime(currentState: int) : Time	
					M28	startTimer() : Time	
					M29	stopTimer() : Time	
					M30	resetTimer() : Time	
					M31	changeMode(currentState: int) : void	
					M32	changeValue(currentState: int) : void	
					M33	changeIndex() : int	WorldtimeMode
					M34	changeMode(currentState: int) : void	
					M35	checkBC() : boolean	BrightcontrolMode
					M36	switchBC() : void	
					M37	initializeBC() : void	
					M38	changeBClevel : int	
					M39	daylong() : void	
					M40	changeMode(currentState: int) : void	
					M41	changeSW() : int[]	SWMode
					M42	enterChangeSW() : void	
					M43	selectSW() : int	